

# Software navigation receivers for GNSS and DVB

F. Vejražka, P. Kovář, M. Eška & P. Puričér

*Czech Technical University in Prague, Prague, Czech Republic*

**ABSTRACT:** We describe the software GNSS receiver, its schema, implementation into a computer, results of tests and application for railway, municipal transportation and for shipping of dangerous matters. The receiver, originally for the Galileo system, is on a printed board which is the size of a Euro Card (160×100 mm). Because the Galileo signal is not in the air, it was modified for the GPS and GLONASS systems. Experimental GNSS receiver (EGR) was used as a tool for its development and it is also described. Even if we use the receiver which is able to process signals of all three systems, it is impossible to ensure reception of GNSS signals in adverse conditions (under leaves canopy, in urban canyons, in hollow tracks, etc.). Therefore we have studied the possibilities of communication systems which will use modern signals known from satellite navigation and we have obtained very interesting results when we used DVB-T transmitters as beacons.

## 1 EXPERIMENTAL GNSS SOFTWARE RECEIVER (EGR)

Requirements of the Czech Ministry of Transport have led us to development of a Galileo navigation receiver. After analysis of state of Galileo system and other GNSS navigation systems we formulated our own requirements on the receiver which have been as follows:

1. The processing of all GPS, GLONASS, SBAS and Galileo signals
2. High flexibility and rapid implementation of the new signal processing
3. Enough performance for the very complex signal processing

Those requirements can be satisfied by the software defined radio (SDR) architecture. The principal schema of the software defined radio is shown on Fig. 1.

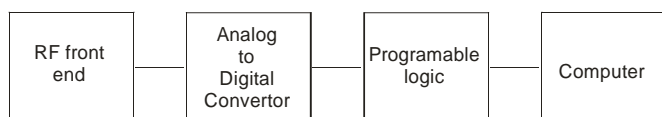

Fig. 1. Block diagram of the SDR receiver solutions

Requirements mentioned above have led to receiver concept which will allow to process signals with wide frequency bandwidth. The signal samples are firstly processed in the programmable logic, where the bandwidth of the signal is reduced and then the signal is processed in a computer. Both programmable logic and the computer can be parts of a FPGA.

Demand of flexible development of hardware and software of the receiver has tended to an experimental hardware platform which would allow very simple replacement of particular components and blocks (radio frequency filters, etc.) and allow very easy creation and realization of signal processing algorithms.

The block diagram of the experimental GNSS receiver is in Fig. 2. The receiver consists of three parts: radiofrequency unit, DSP unit and PC workstation.

The radio frequency unit consists of four independent radio channels which can operate at any frequency in range 1 – 2 GHz. The bandwidth of each channel is 24 MHz; the RF unit supports active and passive GNSS antennas. The intermediate frequency is 140 MHz, gain of the receiver can be controlled either by AGC (>40 dB) loop, either via external input signal by DSP. The output signal of radio frequency unit is digitalized by 8 bit A/D converter with sampling frequency 80 MHz and the remaining signal processing is performed in programmable digital hardware. The advanced FPGA Virtex II Pro by Xilinx with integrated PowerPC processors is applied and placed in prototyping board which has reduced technological demands for FPGA board development and construction.

Main task of connected PC is to be user interface. It also translates programs in Simulink language, runs them, loads them into FPGA and serves as display and control unit for their verification in EGR.

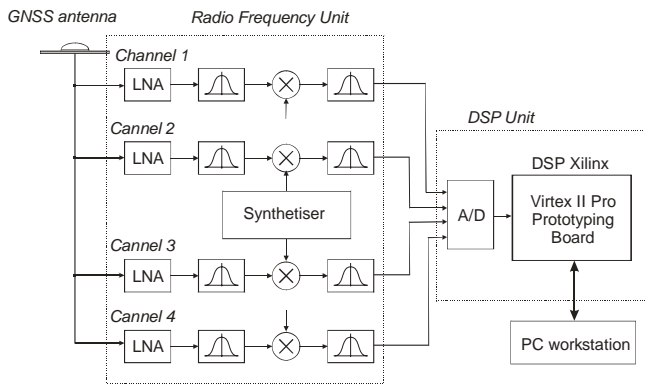

Fig. 2. Block diagram of the Experimental GNSS Receiver (EGR)

The receiver is equipped with switched power supplies and high precision frequency reference with stability 0.03 ppm. The complete receiver mounted into the 19-inch rack is in the Fig. 3. The receiver is capable to process the all known navigation signals except of the Galileo E5 signal. The concept of the modernized version of the experimental receiver with higher performance and capable to process Galileo E5 signal was prepared; receiver is currently in prototype realization state.

EGR has served as a development tool and has been used for development of the GNSS receiver for railway applications.



Fig. 3. Experimental GNSS Receiver in 19-inch rack

## 2 GNSS RECEIVER FOR RAILWAY APPLICATIONS

The Czech Republic is characteristic by its dense railway network because of the long tradition of this kind of transport. Besides of the primary network (railway corridors), which is equipped with the railway signalling interoperable with the systems used by surrounding countries and EU, the secondary railway network is usually safeguarded with the national non compatible systems. The use of GNSS in safety railway system would bring many savings.

Since the position information is to be used by railway station equipment for traffic control and

guaranty of safety in appropriate area, the GNSS receiver as a source of information has to meet reliability, integrity and safety requirements based on common standards for signalling systems (EN 50129).

The main problem of the use of commercial GNSS receiver in railway operations is verification of proper function of its software. Therefore the Ministry of Transport decided to order design of the receiver which algorithms could be documented and proved by a simple way.

The hardware of the designed receiver supports reception and processing of signals of all three systems (GPS L1 C/A, GPS L2C, GLONASS, Galileo E1 and WAAS/EGNOS). Receiver is built on PCB of Euro Card size (160×100 mm, Fig. 4), designed for industry temperature range  $-40 \div +80$  °C and the mechanical construction meets the standards for rail signalling systems. The circuit design utilizes solely modern 3.3V technology. Consumption of the receiver is approximately 4W. Receiver cooling is ensured by the passive cooler with no rotating parts. The receiver was successfully tested as the GPS receiver by the Spirent simulator.

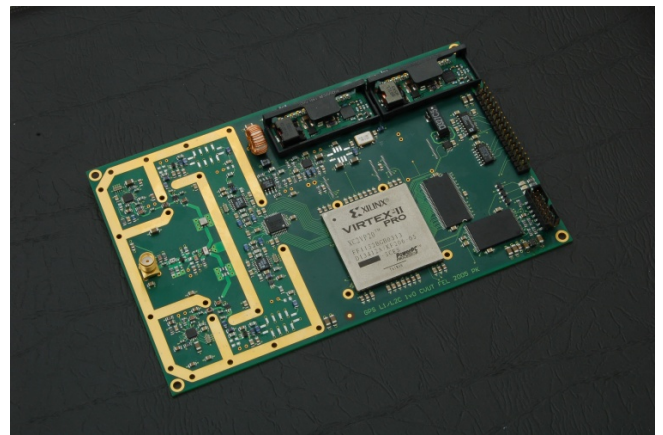

Fig. 4. PCB of the GNSS receiver for railway application

## 3 DVB – T AS A NAVIGATION MEAN

There are problems with the use of GNSS (signal availability and signal power level) in so called hard conditions: under leaves canopy, in urban environment, in hollowed tracks and indoor. Even various methods have been developed to process weak GNSS signals the reliable reception is not satisfied. One method - Assisted GPS (AGPS) – is closely integrated with communication infrastructure. It can imply an idea to use it for navigation; there are a lot of mobile phones providers that use their networks for user position determination. They use Signal Strains (SS), Time of Arrival (ToA) or Differential Time of Arrival (DTToA) navigation methods. But geometry of mobile phones base

stations and their signal properties don't satisfy required precision of position.

Properties of signals of DVB-T transmitters are similar to ranging signals of GNSS systems. We will deal with the exploitation of the DVB-T signal for position determination using ToA or DToA navigation methods. The similar system was described in (Do 2006, Rabinowitz 2003) where American ATSC Digital Television (DTV) signal has been tested for ranging. This DTV system used 8-ary Vestigial Sideband Modulation (8VSB) with symbol rate 10.76223 MHz. The signal delay was derived from the symbol synchronization.

### 3.1 DVB-T signal characteristics

The European standard DVB-T (ETSI EN 2004) is based on OFDM multiplex with OFDM symbol rate of approximately 1 – 4 kHz depending on the mode (2K, 4K or 8K - number of carriers) and signal bandwidth (channel spacing). The OFDM synchronization methods are described in (Keller et al. 2006). The acceptable synchronization error for successful data demodulation is equal to the fraction of symbol duration  $T_U$ , i.e. tens or hundreds of microseconds. This synchronization error corresponds with the range error in the order of kilometers or tens of kilometers, which is not practically usable for navigation.

On the other hand, the minimum accessible deviation  $(\sigma_r^2)_{MIN}$  of the range measurement in additive white Gaussian noise (AWGN) channel (Cook 1969) is determined by (1) and depends on the signal effective bandwidth  $2\beta$ , signal energy  $E$ , and single side spectral power density of the noise  $N_0$

$$(\sigma_r^2)_{MIN} = \frac{c}{2} \cdot \frac{N_0}{2E\beta^2} \quad (1)$$

where  $c$  is speed of light,

$$\beta^2 = \frac{4\pi^2}{2E} \int_{-\infty}^{\infty} f^2 |\tilde{S}(f)|^2 df \quad (2)$$

and  $|S(f)|$  is spectral energy density of the processed signal complex envelope. The optimal signal processing is based on correlation reception.

### 3.2 Correlation reception and simulation results

The correlation reception is based on the computation of the cross correlation function of the processed signal and its known replica. The signal delay is determined by position of the maximum of this function. Thanks to the good signal to noise

ratio, the DVB-T signal has not to be processed continuously like GNSS signal to reach reasonable measurement error. It is sufficient to work with snapshots of the signal. The following analysis focuses on processing of one OFDM symbol duration snapshots in 8K mode, which is typical mode for the DVB-T service in the Czech Republic.

The DVB-T signal (ETSI EN 2004) consists of the transmitted data  $s_d(t)$ , scattered pilot cells  $s_{sp}(t)$ , continual pilot carriers  $s_{cp}(t)$ , and TPS carriers  $s_{TSP}(t)$

$$s_{DVB}(t) = s_d(t) + s_{sp}(t) + s_{cp}(t) + s_{TSP}(t). \quad (3)$$

The OFDM symbol with duration  $T_S$  consists of symbol part  $T_U$ , which is extended by the guard interval  $\Delta$ . All components of the OFDM symbol are orthogonal for the symbol part duration  $T_U$ .

The method of replica generation uses a part of the DVB-T signal only, for example continual pilot carriers, and the rest part of the signal is assumed as a signal modulated by the random data. The benefit of this procedure is the fact that such proper part of signal is identical in every symbol and is orthogonal to the rest of signal components in vicinity of the correlation maximum. It means that those random signals do not affect the range determination. The weakness of this procedure can be seen in the fact that only small part of the signal energy is used for ranging.

The simulated range measurement errors obtained by the application of the method described above are in Fig. 5. The theoretical values of standards deviation of range error (1) and simulated ones for various SNR are compared in Table 1.

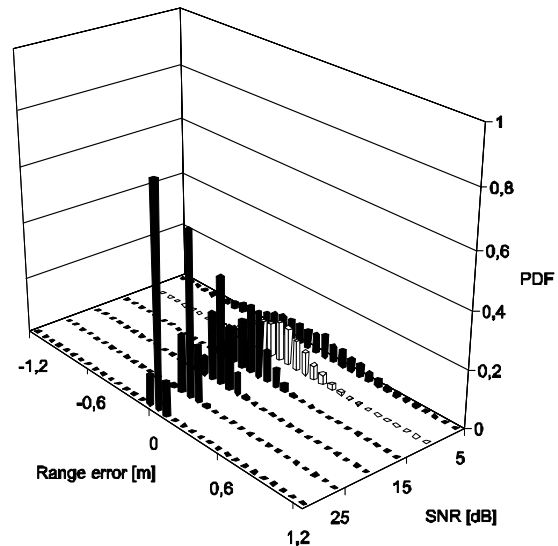

Fig. 5. PDF of range measurement error of the DVB-T signal

The ranging performance (see Table 1) of the DVB-T signal is very good despite of the fact that only continual carrier part of the DVB-T signal was

used for range estimation. This is thanks to wide bandwidth of the DVB-T and good signal to noise ratio in the service area.

Table 1. DVB-T 8K Signal Range Measurement Error

SNR [db]	$\sigma_r$ [m] theory	$\sigma_r$ [m] simulation
5	0.487	0.422
10	0.274	0.224
15	0.144	0.134
20	0.086	0.079
25	0.048	0.046
30	0.028	0.031

The comparable range measurement error in GNSS receiver can be reached by long averaging process (Kaplan 2003). The computational requirements to the DVB-T signal processing for obtaining comparable error are therefore much lower than for the case of the GNSS signal processing.

### 3.3 Multipath sensitivity

Multipath is the main part of errors of the navigation systems based on ToA or DToA navigation method. Error can be expressed by so called multipath error envelope, which shows the worst positive and negative measurement errors for the channel with one straight and one reflected delayed signal (Misra & Enge 2001). Power level of the reflected signal is expressed by the Multipath-to-Direct Ratio (MDR).

The range error caused by the multipath is lower for the DVB-T than for the GPS C/A because of the wider signal bandwidth (Fig. 6). However the multipath error in DVB-T signal ranging is negatively influenced by the relatively high adjacent correlation peaks.

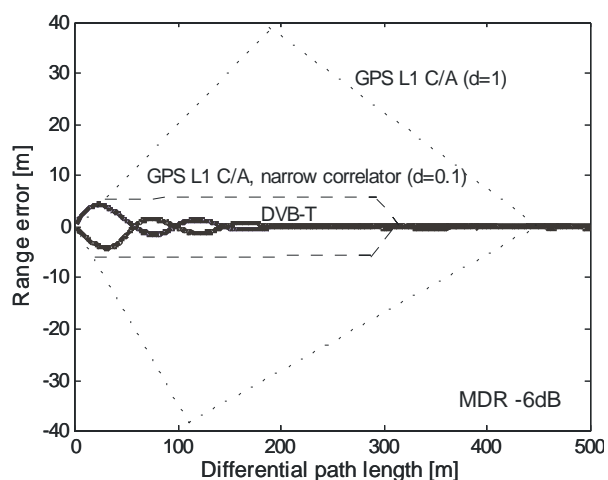

Fig. 6. Multipath error envelope of DVB-T and GPS (d is GPS correlator spacing)

### 3.4 Software receiver for DVB-T ranging (Fig. 7)

Precision of the position determination of the ToA or DToA systems depends on the signal arrival time measurement error, transmitters–receiver geometry and propagation effects, e.g. multipath. The software DVB-T receiver was developed for further investigation of ranging performance, propagation phenomena and positioning tests. The receiver captures snapshots of the DVB-T signals on various frequencies and sends them via USB interface to the PC workstation. Because of the low computational complexity of the signal processing, the real time signal processing has been programmed in Matlab environment.

## 4 CONCLUSIONS

The Experimental Software GNSS Receiver is the tool for experiments with real GNSS signals which cannot be carried out with the commercial receivers. Its main advantage is versatility. The utilization of the modern development tools for FPGA, signal processing and embedded computers supports rapid implementation of the investigated algorithms to the receiver.

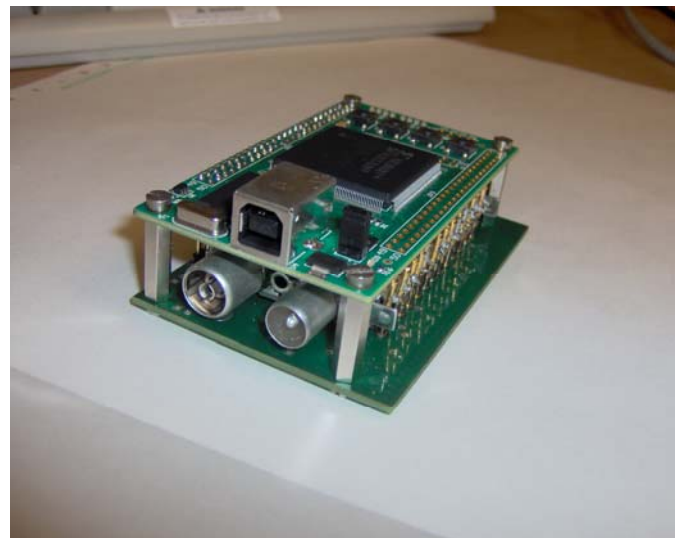

Fig. 7. Experimental DVB-T receiver for navigation

Processing of the wideband Galileo E5 signals requires more powerful algorithms and therefore next generation of EGR will be based on Virtex 4 FPGA with higher performance. It will be able to process all Galileo signals in space.

First analysis and experiments indicate that DVB-T signal can be used for mobile navigation based on ToA or DToA positioning principles. The range measurement errors are comparable with the measurement errors of the GPS. Moreover, the DVB-T signal is available indoor at sufficient level. The DVB-T ranging can be used in stand alone

navigation system or it can be integrated with other navigation systems.

The next research will be focused on study of errors caused by the propagation of the DVB-T signal and transmitters' geometry. The other technical problem to be solved is determination of the OFDM symbol timing or symbol synchronization to the UTC or GPS time with precision of one nanosecond and better.

## ACKNOWLEDGEMENT

Research described in the paper was financially supported by the research program MSM 6840770014 of the Czech Ministry of Education.

## REFERENCES

- Bertoncini B., Luise M., Principe F. & Terzi M., 2004. SOFT-REC: An Innovative GPS Receiver following the Software Radio Paradigm. *Proceedings of NAVITEC 2004*, 2<sup>nd</sup> ESA Workshop on Satellite Navigation User Equipment Technologies. Noordwijk: ESA, pp.25-26.
- Borre K. et al. 2007a., *A software-Defined GPS and Galileo Receiver, A Single-Frequency Approach*. Boston: Birkhauser.
- Borre K., 2007b. The GPS Easy Suite—Matlab code for the GPS newcomer. *GPS Solutions*, no 7, pp 47-51.
- Cook Ch. C. & Bernfeld M., 1969. *Radar Signals, An Introduction to Theory and Application*. Academic Press.

- Do J., Rabinowitz M. & Enge P., 2006. Performance of Hybrid Positioning System Combining GPS and Television Signals. *Proceedings of the Position Location and Navigation Symposium - PLANS 2006*, pp. 556-564.
- ETSI EN, 2004. Digital Video Broadcasting (DVB); Framing structure, channel coding and modulation for digital terrestrial television. *ETSI EN 300 744 V1.5.1*
- Kaplan D., 2003. *Understanding GPS Principles and Applications*. Artech House Inc.: London
- Keller T., Piazza L. & Mandarini P., 2006. Orthogonal Frequency Division Multiplex Synchronization Techniques for Frequency-Selective Fading Channels. *IEEE Journal on Selected Areas in Communication*, vol. 19, no. 6, pp. 999-1007.
- Kovář P., Vejražka F., Seidl L., & Kačmařík P., 2003. Experimental Software Receiver of Signals of Satellite Navigation Systems. *11th IAIN World Congress on Smart Navigation - Systems and Services*. Berlin.
- Kovář P., Vejražka, F & Špaček, J. 2004. Availability of the EGNOS System for a Land Mobile User. *The International Symposium on GPS/GNSS*. Sydney.
- Kovář P., Seidl L. & Vejražka F., 2006. Availability of the EGNOS Service for a Land Mobile User. *Proceedings of the Position Location and Navigation Symposium - PLANS 2006* [CD-ROM]. Piscataway: IEEE, pp. 524-530.
- Kovář P., Puričar, P. & Špaček, J. 2006. Design Methods for RF Part of the GNSS Software Receivers. *Coordinates*, Vol. 2, No. 4, pp 34-37.
- Misra P. & Enge P., 2001, *Global Positioning Systems, Signals, Measurements, and Performance*. Ganga-Jamuna Press.
- Rabinowitz M. & Spilker J., 2003 "A new positioning system using television synchronization signals. *IEEE Transactions on Broadcasting*, vol.51, no.1 , pp 51-61.